



# WorkShop Sindifar RS

## 21/03/2014

Rafael Latorre – Antares Vision **Brasil**

## Antares Vision – USA

### 4- New York:

- Escritório Adm. e Vendas
- Serviço Técnico e Engenharia
- FAT

## Antares Vision – Brasil

### 5- São Paulo :

- Escritório Adm. e Vendas
- Serviço Técnico e Engenharia
- FAT
- Produção de máquinas (> 1/3 2014)

## Antares Vision - Alemanha

### 3 - Frankfurt:

- Escritório Adm. e Vendas
- Processamento de imagem P&D (CÂMERAS)
- Desenvolvimento de hardware
- Serviço técnico e Engenharia

## Antares Vision - Itália

### 1- HQ Brescia:

- Escritório Central Adm. e Vendas
- Desenvolvimento de Software
- Serviço Técnico e Engenharia
- FAT
- Produção de máquinas

### 2- Roma:

- Produção de máquinas
- Serviço técnico e Engenharia
- FAT

## Antares Vision - Itália

### 1- HQ Brescia:



### Antares Vision - Itália

### 2- Roma:



### Antares Vision - Alemanha

### 3 - Frankfurt:



### Antares Vision - USA

### 4- New York:



### Antares Vision - Brasil

### 5- São Paulo :



## COMERCIAL < 2013



● Pré-venda (Análise e Estudo de Viabilidade).



● Vendas (Negociação, Importação e Entrega).



● Pós Venda e Peças de reposição e consumíveis (Estoque Local ).

## SERVIÇO < 2013



● Instalação, Startup e Treinamento (Engenheiros e Técnicos - local).



● Assistência Técnica local 24/7 (Engenheiros e Técnicos - local).



● Assistência Técnica - Remota 24/7 (TI e Software - local ).



● Serviço de manutenção preventiva.



● Serviço de Qualificação e Validação (Equipe local)



● Laboratório de testes, amostras e relatório de resultados.

## INDUSTRIAL > 2014



● Produção local de máquinas (Transferência de tecnologia AV – Itália).



● FAT no Site Antares Vision – Brasil.



● Integração/Retrofit em máquinas existentes (encartuchadra, rotuladora, emblistadeira e Case Packer).



● Modificações e Automação dentro do Site Antares Vision – Brasil.



● Confeção e desenvolvimento de componentes mecânicos (customizado).

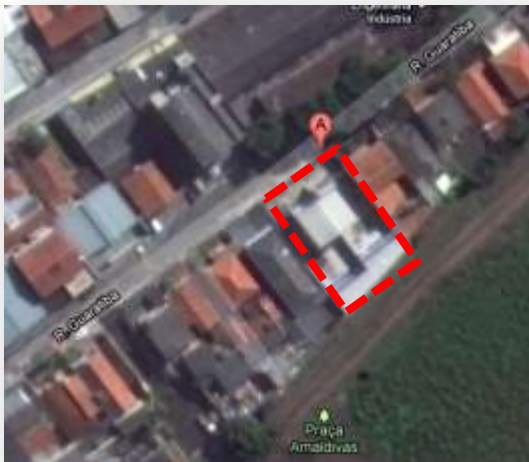

### Antares Vision - Brasil

Rua Guaratiba, 132  
Santo Amaro - São Paulo  
+55 11 2364-7512

[www.antaresvision.com.br](http://www.antaresvision.com.br)



# Track & Trace Antares Vision Experiência – referências



INDÚSTRIA QUÍMICA E FARMACÉUTICA, S.A



YOUR INSPECTION AND TRACEABILITY PARTNER

# Track & Trace Antares Vision

## Experiência > 2012



### ACREDITE EM FATOS

- ✓ **350** MÓDULOS DE SERIALIZAÇÃO
- ✓ **150** LINHAS COM AGREGAÇÃO EM COMPLETO FUNCIONAMENTO
- ✓ METODOLOGIA **OEE** DE OTIMIZAÇÃO
- ✓ SOLUÇÃO 100% **TURNKEY**
- ✓ TECNOLOGIA DE **HARDWARE & SOFTWARE** PRÓPIO

**ROEMMERS** Argentina

**SANDOZ** Austria

**GE-PH** Bulgaria

**LGV** France

**MAYOLY** France

**GRIMBERG** France

■ N° OF OPERATIONAL AGGREGATION LINES  
■ N° OF OPERATIONAL SERIALIZATION LINES

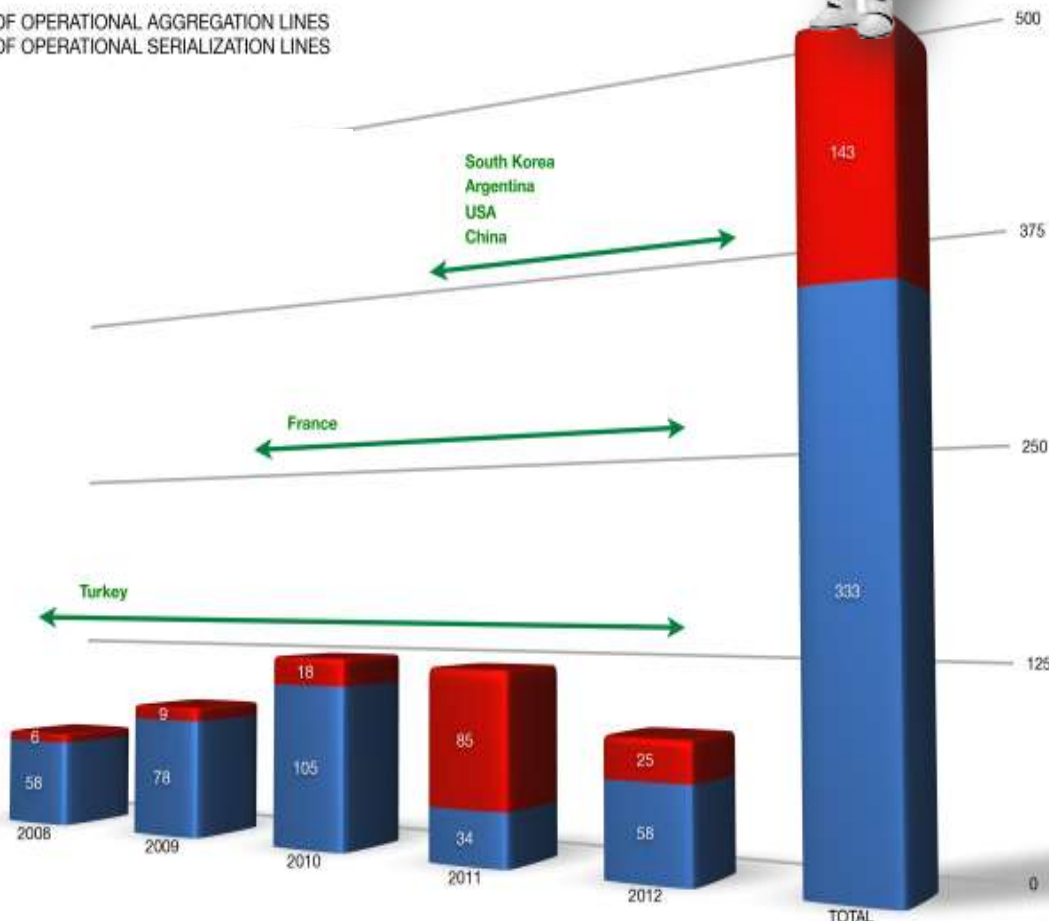

YOUR INSPECTION AND TRACEABILITY PARTNER

# Track & Trace Antares Vision

## Experiência > 2013



- 1 -  **Abbott**
- 2 - **ALLERGAN**
- 3 - **astellas**
- 4 -  **FERRING**
- 5 -  **GILEAD**
- 6 -  **JANSSEN-CILAG**
- 7 - **L E O**
- 8 -  **NOVARTIS**
- 9 -  **SANDOZ**
- 10 -  **MSD**
- 11 -  **Recipharm**  
good for business
- 12 - **SANOFI**
- 13 -  **Takeda**
- 14 -  **TEVA**

A **ANTARES VISION** FOI AUDITADA  
POR **14** EMPRESAS EM 2013.

### QUESTÕES :

- ✓ QUALIDADE SW & HW
- ✓ OPERACIONALIDADE HW & SW
- ✓ DOCUMENTAÇÃO
- ✓ VALIDAÇÃO
- ✓ CAPACIDADE PRODUTIVA
- ✓ ASSISTÊNCIA TÉCNICA

### RESULTADO:

OBTENÇÃO DE **100%** DE APROVAÇÃO  
COMO PROVEDORES DE SOLUÇÕES  
TRACK & TRACE PARA  
HW E SW EM NÍVEL GLOBAL.



# NOVA SEDE 4.500m<sup>2</sup>

## **Antares Vision - Itália** **HQ Brescia:**

- **Escritório Central Adm. e Vendas**
- **Desenvolvimento de Software**
- **Desenvolvimento de Hardware**
- **Serviço Técnico e Engenharia**
- **FAT**
- **Produção de máquinas**



**- 1800m<sup>2</sup>  
Produção**

**- 2700m<sup>2</sup>  
Software&Hardware**

**Inauguração  
Agosto 2014**



# Antares Vision Qualidade e Validação



## •ANTARES VISION É CERTIFICADA



O SOFTWARE ATS - ANTARES VISION PROVOU INTEROPERAR COM UMA OU MAIS APLICAÇÕES SAP® UTILIZANDO TECNOLOGIAS DE INTEGRAÇÃO COMO UMA INTERFACE DE PROGRAMAÇÃO BAPI®, CHAMADO DE FUNÇÃO REMOTA (RFC) OU DOCUMENTO DE TECNOLOGIA INTERMEDIÁRIA (IDOC)

**SAP® Certified**  
Integration with SAP Applications

## •VALIDAÇÃO E CERTIFICAÇÃO

A ANTARES VISION É TOTALMENTE CAPAZ DE SUPORTAR PROCESSOS DE QUALIDADE E VALIDAÇÃO DE DOCUMENTOS DE HABILITAÇÃO COM DETALHES CONCEBIDOS DE ACORDO COM AS DIRETRIZES DO CGMP, OS CINCO PADRÕES GAMP RELEVANTES, UNI EN ISO 9001 E AS RECOMENDAÇÕES DO FDA (CFR21PART11)



### •ANTARES VISION – PACOTE DE DOCUMENTAÇÃO



● **PACOTE BÁSICO DE DOCUMENTAÇÃO—HW/SW**

● **PACOTE COMPLETO DE DOCUMENTAÇÃO—HW/SW**

● **PACOTE DE DOCUMENTAÇÃO GLOBAL- CORPORATIVO MUNDIAL HW/SW**

● **User Requirements Specifications**

● **Validation Plan**

● **Risk Analysis**

● **Traceability Matrix**

● **Functional Design Specification**

● **Software Design Specification**

● **Hardware Design Specification**

● **IQ/OQ Protocol**

● **FAT Protocol**

● **SAT Protocol**

● **Support to Customer SOPs upgrade**

● **Validation Report**

# Track & Trace Antares Vision

## Conceito de redundância da informação



Cartucho  
único

- Atribuído – quando a ordem de trabalho é atribuída Ex.: SAP, IBM, Jdedwards, BPCs,



Caixa de  
embarque

- Verificado – quando é impresso e verificado por uma camera.



Palet

- Embalado – quando positivamente empacotados em um caixa de embarque. (CASE PACKER OU MANUAL)

- Paletizado – quando positivamente empacotados em uma pallet.

- Retiradas para controle de qualidade

- Rejeitado

# Track & Trace Antares Vision



**100 % RASTREABILIDADE**

Solução completa de rastreabilidade de medicamentos para a indústria farmacêutica



[www.antaesvision.com](http://www.antaesvision.com)

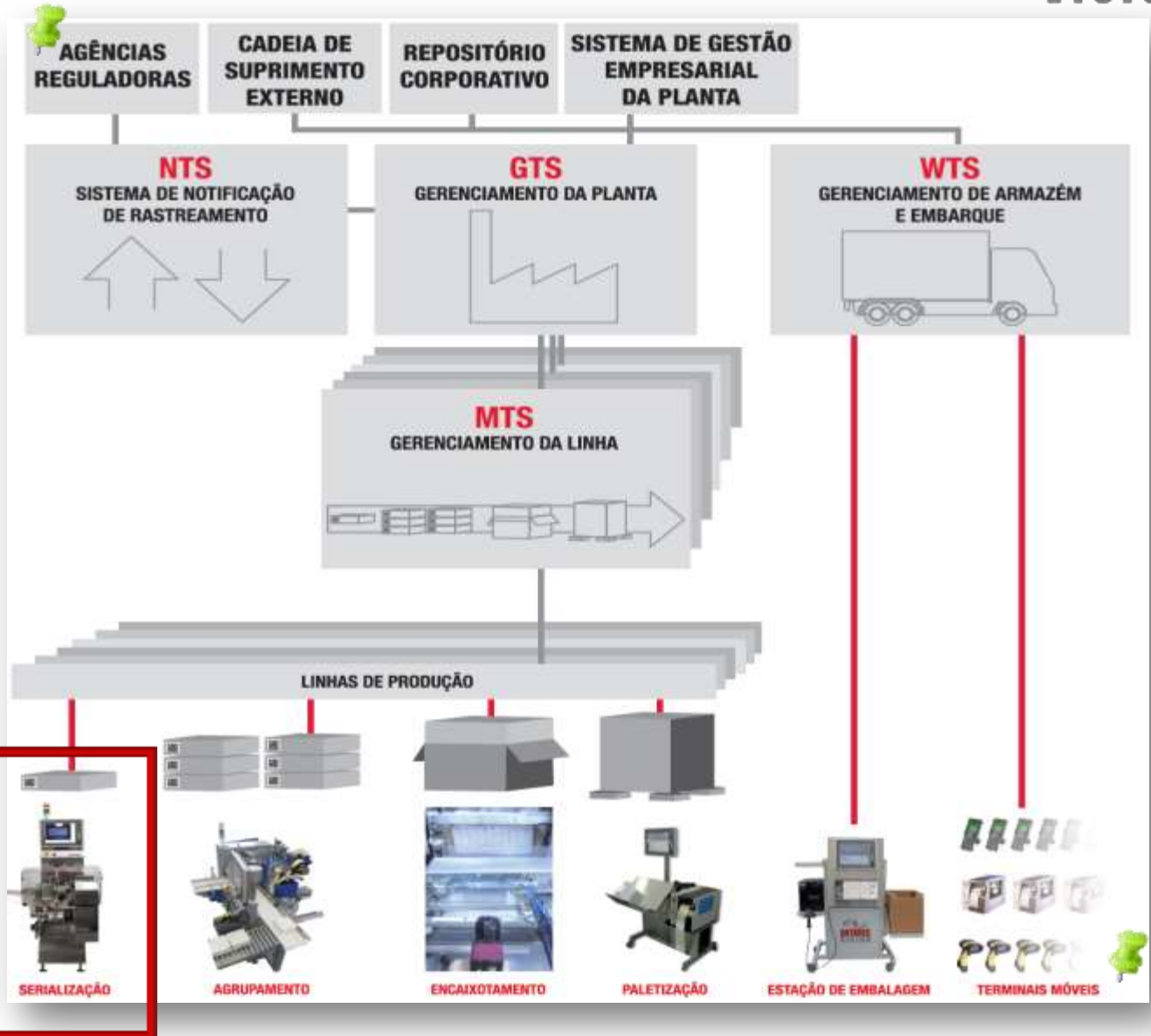

YOUR INSPECTION AND TRACEABILITY PARTNER

# Track & Trace Antares Vision Serialização – Item Cartucho único



HP INKJET QUALIDADE A DE  
IMPRESSÃO ISO 15415-ATÉ 400 P/M

IHM DE 15 POLEGADAS TOUCH SCREEN  
CFR 21 PART 11

CÂMERAS DE ALTA RESOLUÇÃO COM  
ILUMINAÇÃO INTERNA

AVALIAÇÃO ONLINE DA QUALIDADE DE IMPRESSÃO

HAND SCANNER – RECONCILIAÇÃO DE DADOS

VASTA EXPERIÊNCIA DE INTEGRAÇÃO EM MAQUINAS  
NOVAS OU JÁ EXISTENTES DE TODOS FABRICANTES MUNDIAIS



YOUR INSPECTION AND TRACEABILITY PARTNER

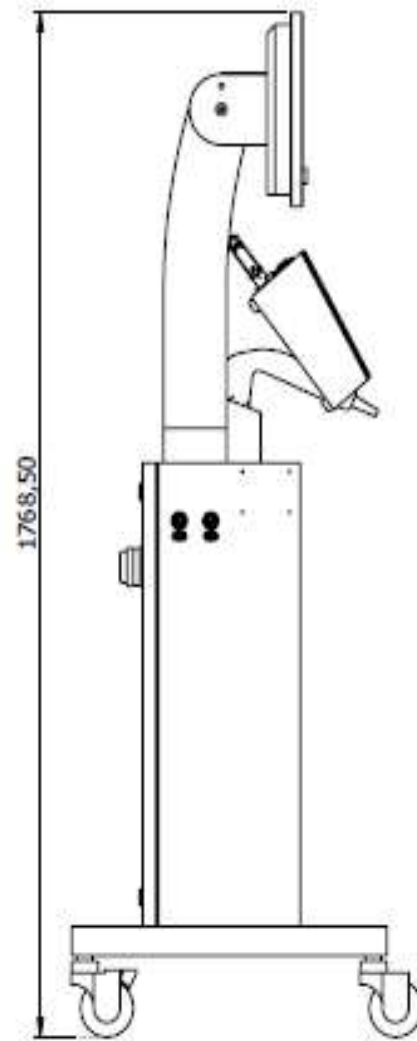
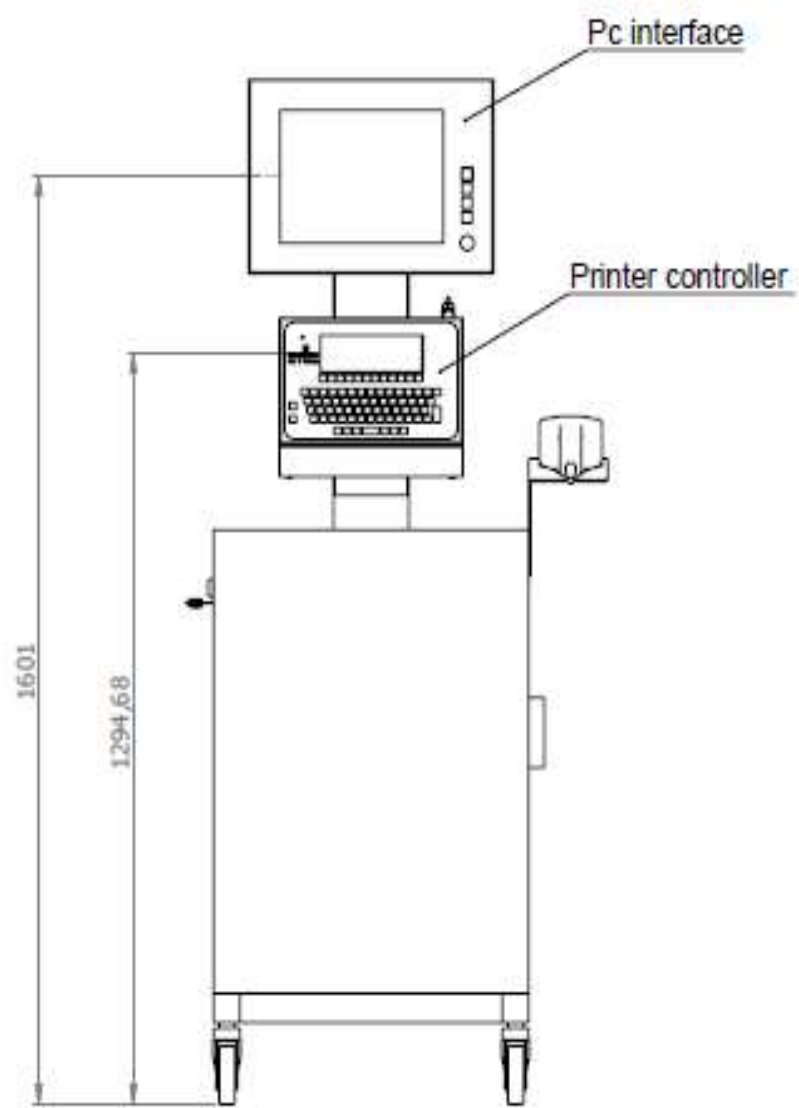



YOUR INSPECTION AND TRACEABILITY PARTNER



# Track & Trace Antares Vision Serialização – Item Cartucho único



**300 CARTUCHOS / MINUTO**

**IMPRESSORA E CAMERA**



**DETALHE DA ESTEIRA  
TRANSPORTADORA**

**PERFEITA ESTABILIDADE  
DO CARTUCHO**

**600MM E RÁPIDA INTALAÇÃO MINIMIZANDO  
POSSÍVEL PARADA DE PRODUÇÃO ( 3DIAS)**

YOUR INSPECTION AND TRACEABILITY PARTNER

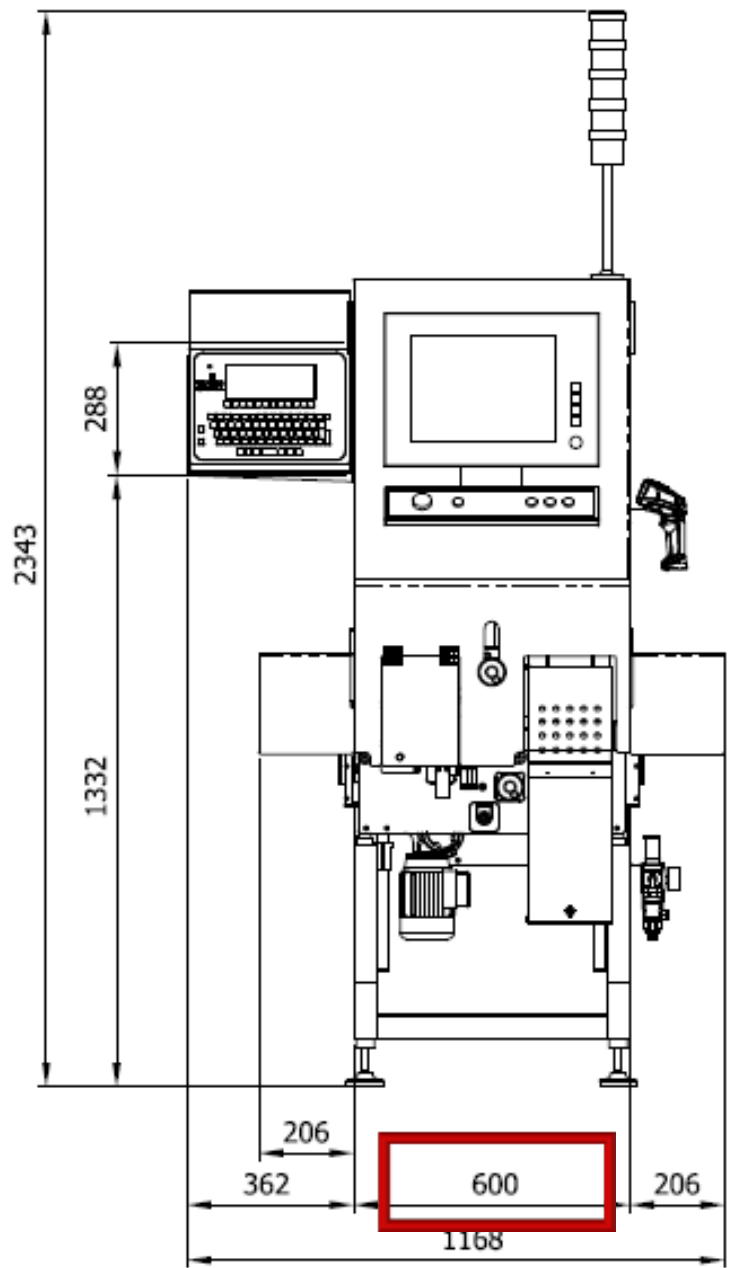
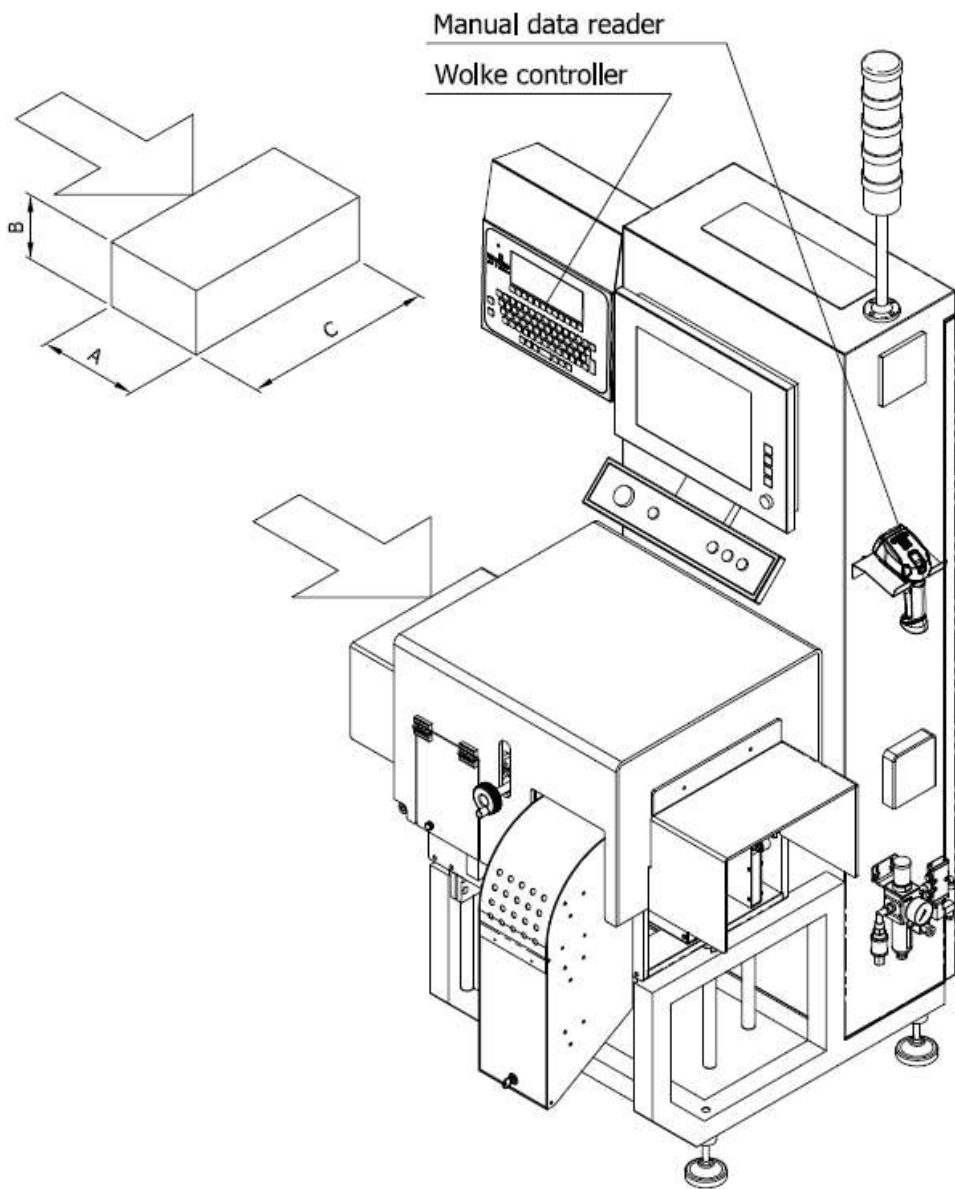



EMPLOYMENT  
TRACEABILITY

# Track & Trace Antares Vision Serialização – Item Cartucho único



**300 CARTUCHOS / MINUTO**

**IMPRESSORA E CAMERA**



**DETALHE DA BALANCA  
DINAMICA INTEGRADA**

**•QUANDO NÃO HÁ  
ESPACO FISICO NA LINHA**



**1000MM E RÁPIDA INTALAÇÃO MINIMIZANDO  
POSSÍVEL PARADA DE PRODUÇÃO ( 3DIAS)**

YOUR INSPECTION AND TRACEABILITY PARTNER

# Track & Trace Antares Vision Serialização – Item Cartucho único



## EXEMPLO DE IMPRESSÃO E VERIFICAÇÃO EM MÓDULO ÚNICO INSTALADO EM LINHA MANUAL





**YOUR INSPECTION AND TRACEABILITY PARTNER**



Artares Tracking System  
**SERIALIZATION  
MODULE**

YOUR INSPECTION AND TRACEABILITY PARTNER

# Track & Trace Antares Vision Serialização – Item Cartucho único



**IMPRESSORA  
E CAMERA**

**APLICAÇÃO  
DE RÓTULOS OU  
ETIQUETA RFID**

**IMPRESSÃO: LATERAL E SUPERIOR**



**DETALHE DA ESTEIRA  
TRANSPORTADORA**

**ALTA PERFORMANCE  
TRANSPORTE LÓGICO  
POSITIVO**



**1350MM E RÁPIDA INTALAÇÃO MINIMIZANDO  
POSSÍVEL PARADA DE PRODUÇÃO ( 3DIAS)**



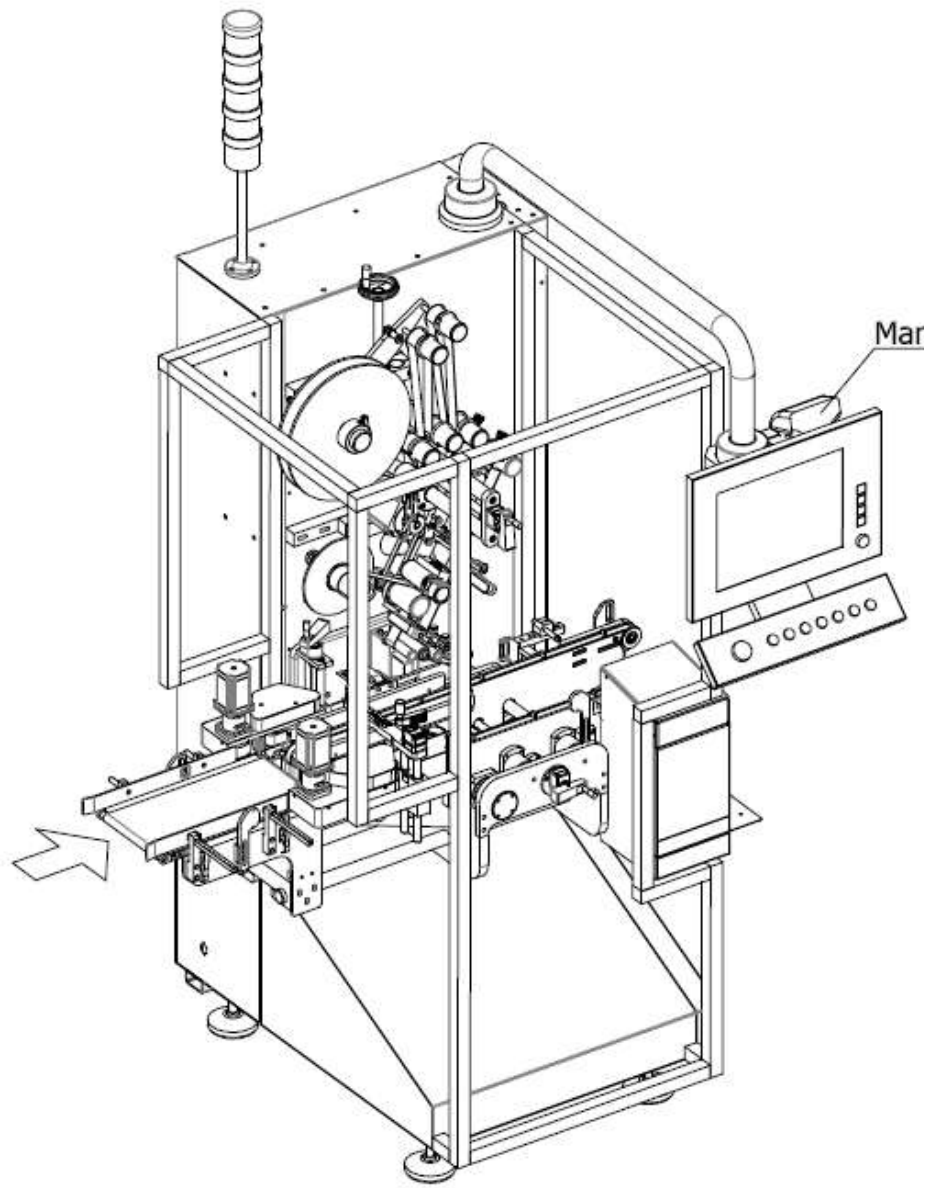

2346

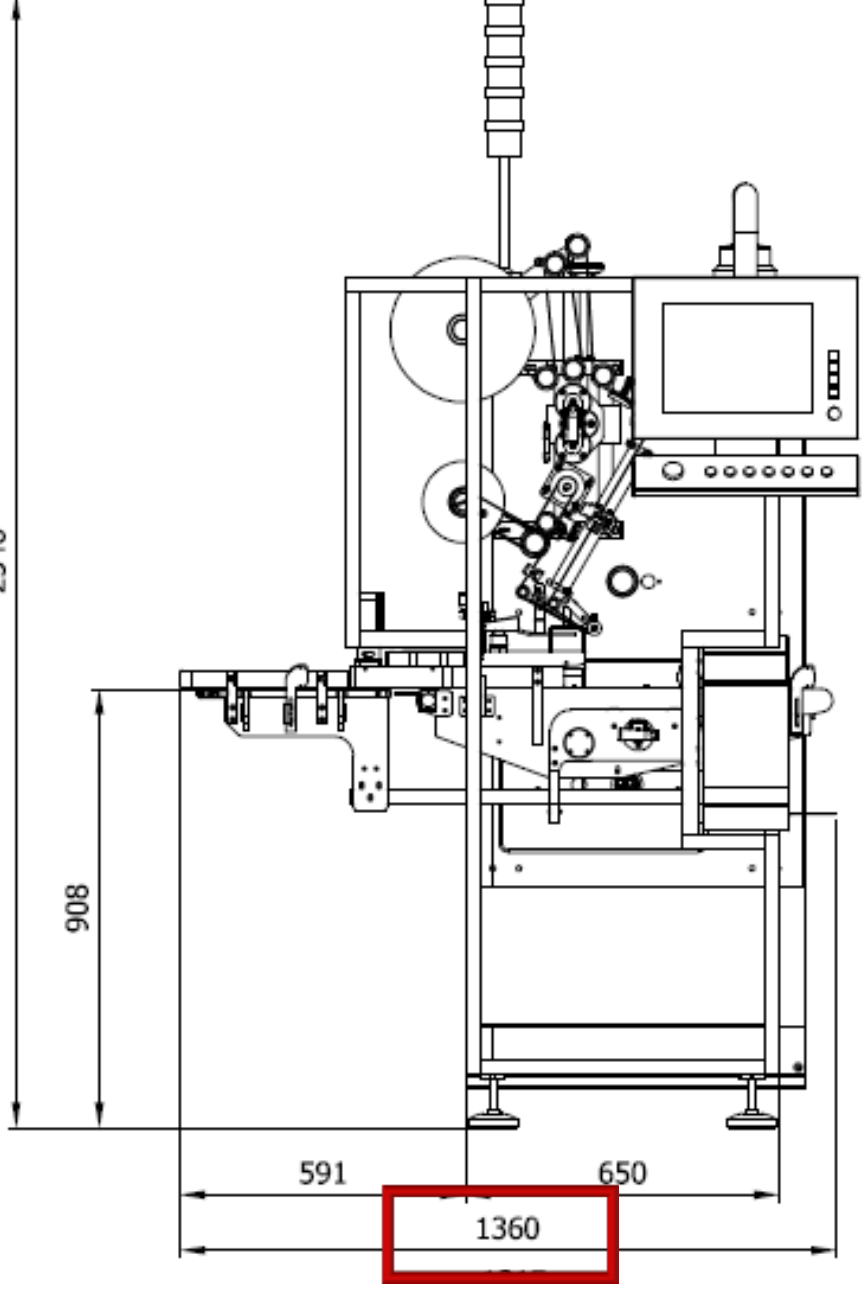

908

591

650

1360

# Track & Trace Antares Vision Serialização – Item Cartucho único



## EXEMPLO DE IMPRESSÃO E VERIFICAÇÃO EM MÓDULO ÚNICO INSTALADO EM LINHA AUTOMÁTICA DE ALTA PERFORMANCE



# Track & Trace Antares Vision Serialização – Item Frasco único



**300  
FRASCOS  
/ MINUTO**



**CONCEITO 360°**

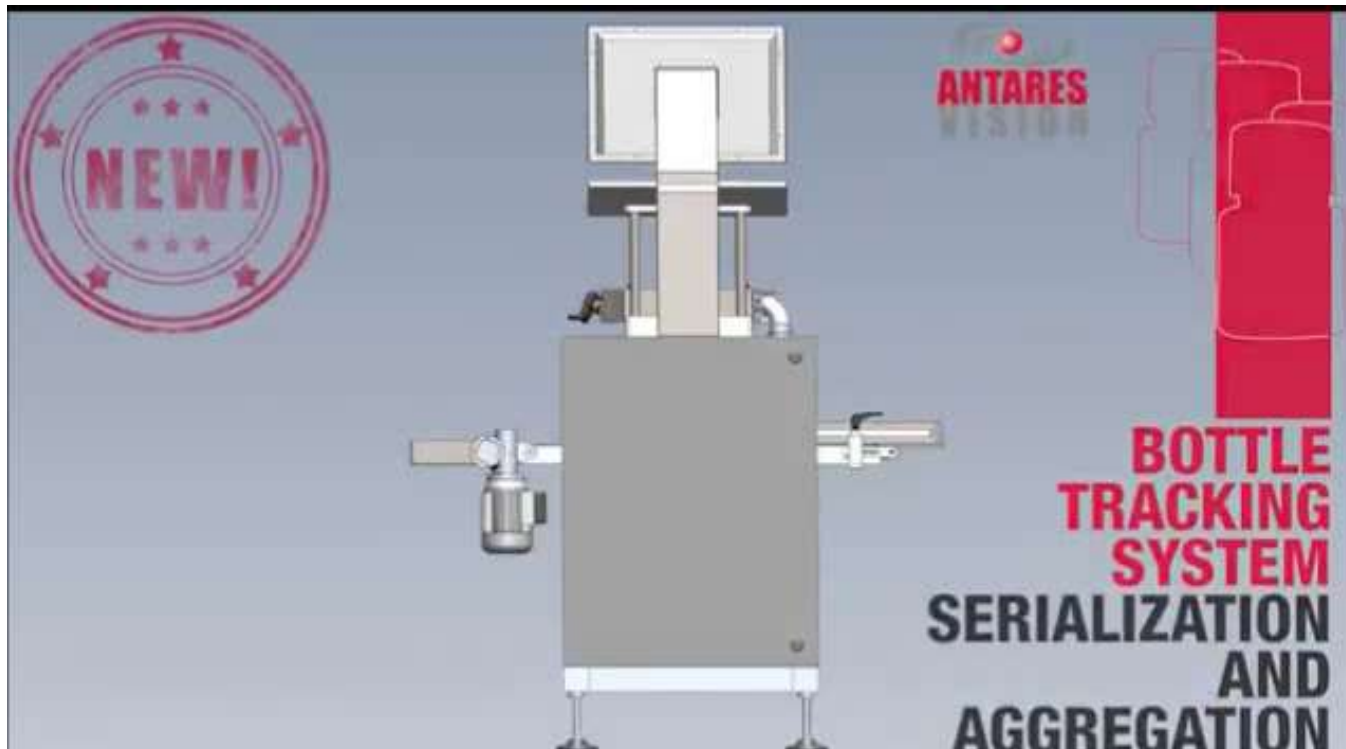

YOUR INSPECTION AND TRACEABILITY PARTNER

# Track & Trace Antares Vision



**100 % RASTREABILIDADE**

Solução completa de rastreabilidade de medicamentos para a indústria farmacêutica

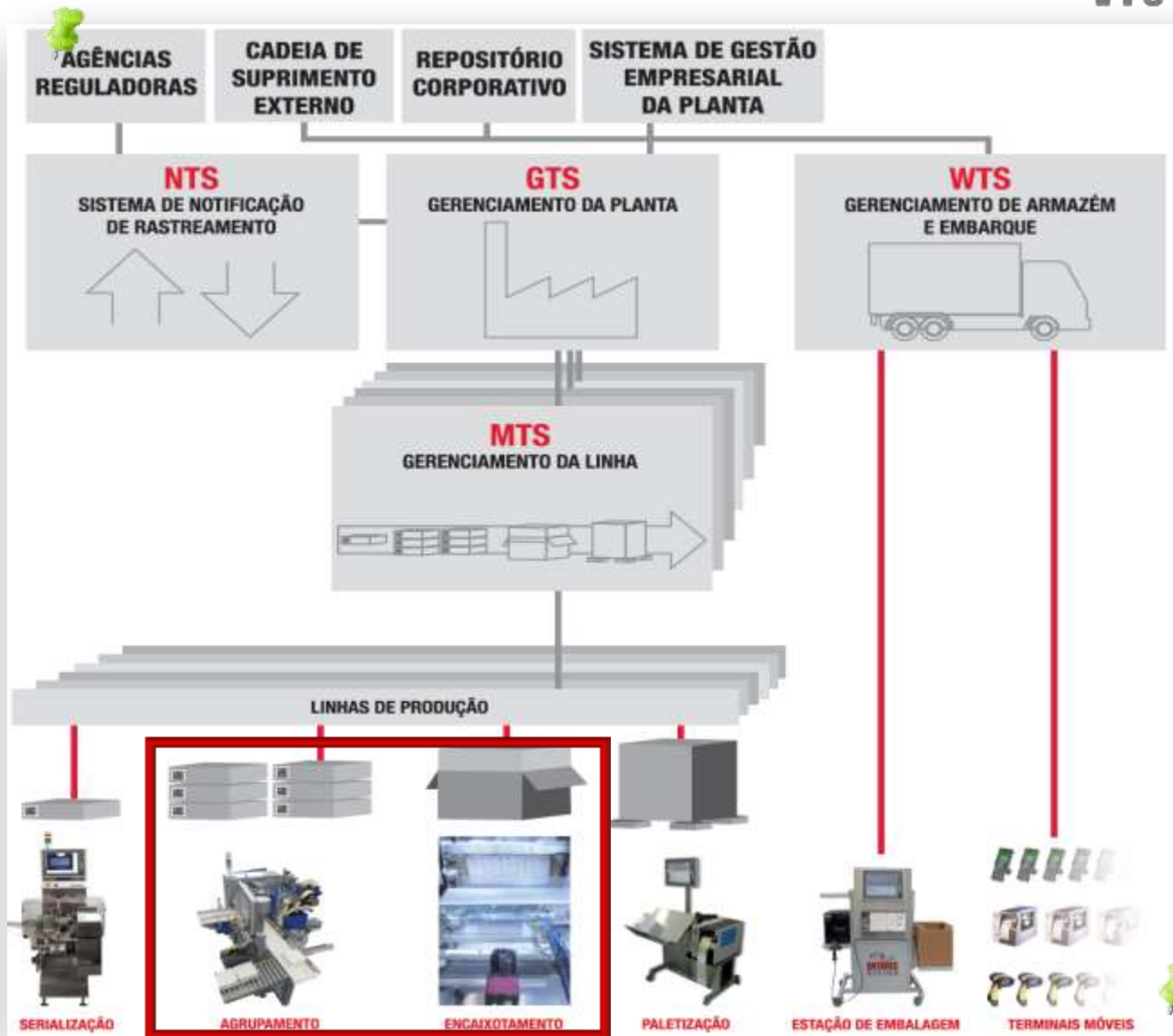

YOUR INSPECTION AND TRACEABILITY PARTNER

# Track & Trace Antares Vision

## Agregação – Múltipla leitura de caixas de embarque



IMPRESSORA DE ETIQUETAS ON LINE –  
SERIAL CAIXA DE EMBARQUE

IHM DE 15 POLEGADAS TOUCH SCREEN  
CFR 21 PART 11

CÂMERAS DE ALTA RESOLUÇÃO COM  
ILUMINAÇÃO INTERNA  
AVALIAÇÃO ONLINE DO GRADE DA IMPRESSÃO

HAND SCANNER – RECONCILIAÇÃO DE DADOS



OPÇÃO PARA PROCESSOS:

1 MANUAL

2 SEMI AUTOMATICO

3 AUTOMATICO



YOUR INSPECTION AND TRACEABILITY PARTNER

**EXEMPLO DE LEITURA MULTIPLA**  
**EM CAIXA DE EMBARQUE INSTALADO EM CASEPACKER**

- Para até 3 camadas de cartuchos
- Megapixel Camera AV 16 megapixel:  
para adquirir com uma única imagem  
de alta resolução todos os códigos  
Datamatrix  
600x550mm de dimensões
- VASTA EXPERIENCIA  
COMPROVADA EM INTEGRAÇÃO  
COM CASE PACKERS:



LEITURA 100%

### CONCEITOS E APLICAÇÕES

- 1- Conceito de Leitura por camada
- 2- Conceito de Leitura por coluna
- 3 – Customizada ( reconstrução )
- 4- Conceito de Leitura dentro de caixa de embarque
- 5- Conceito de leitura Last code reader

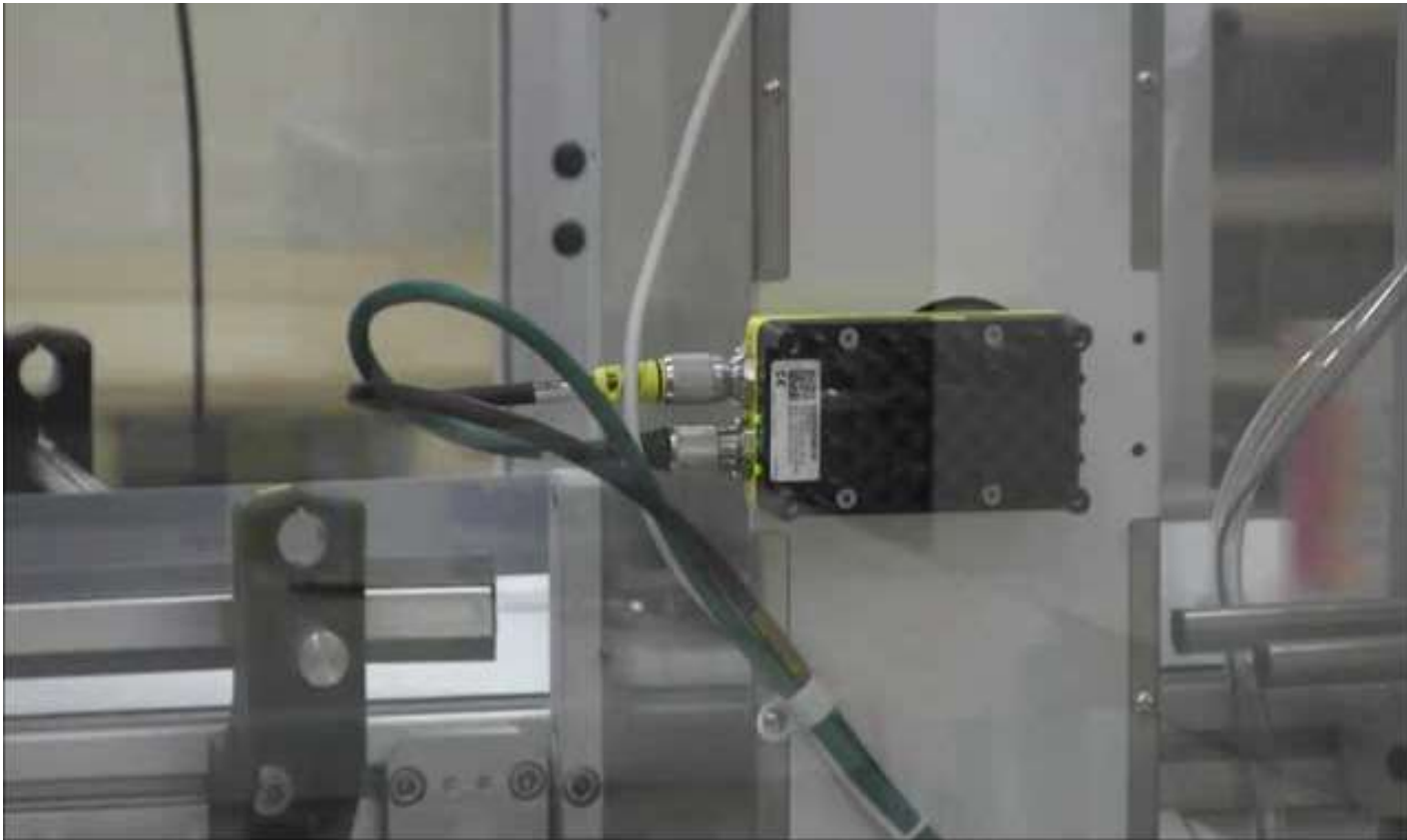

# Track & Trace Antares Vision AGREGAÇÃO – Item CAIXA DE EMBARQUE



- Para até 3 camadas de cartuchos
- ERGONOMICAMENTE DESENVOLVIDO



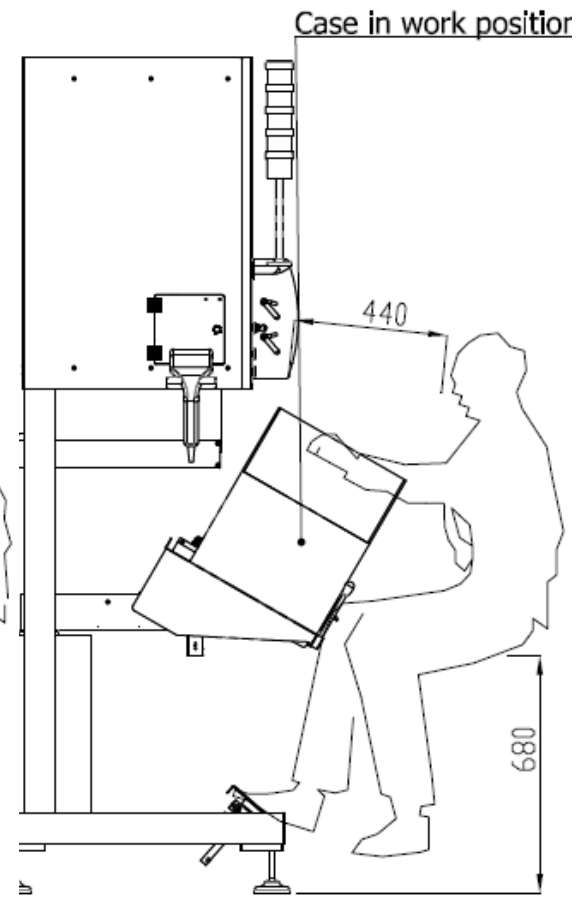
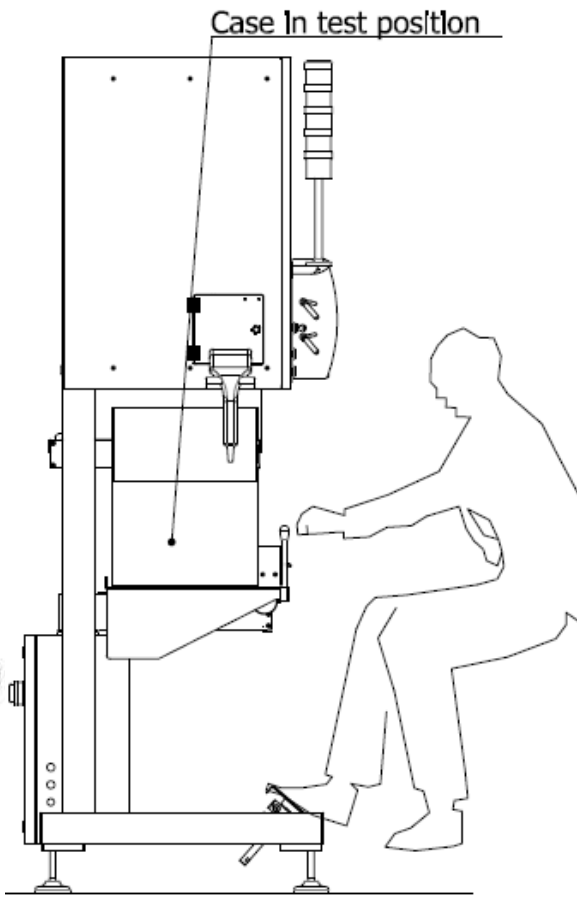
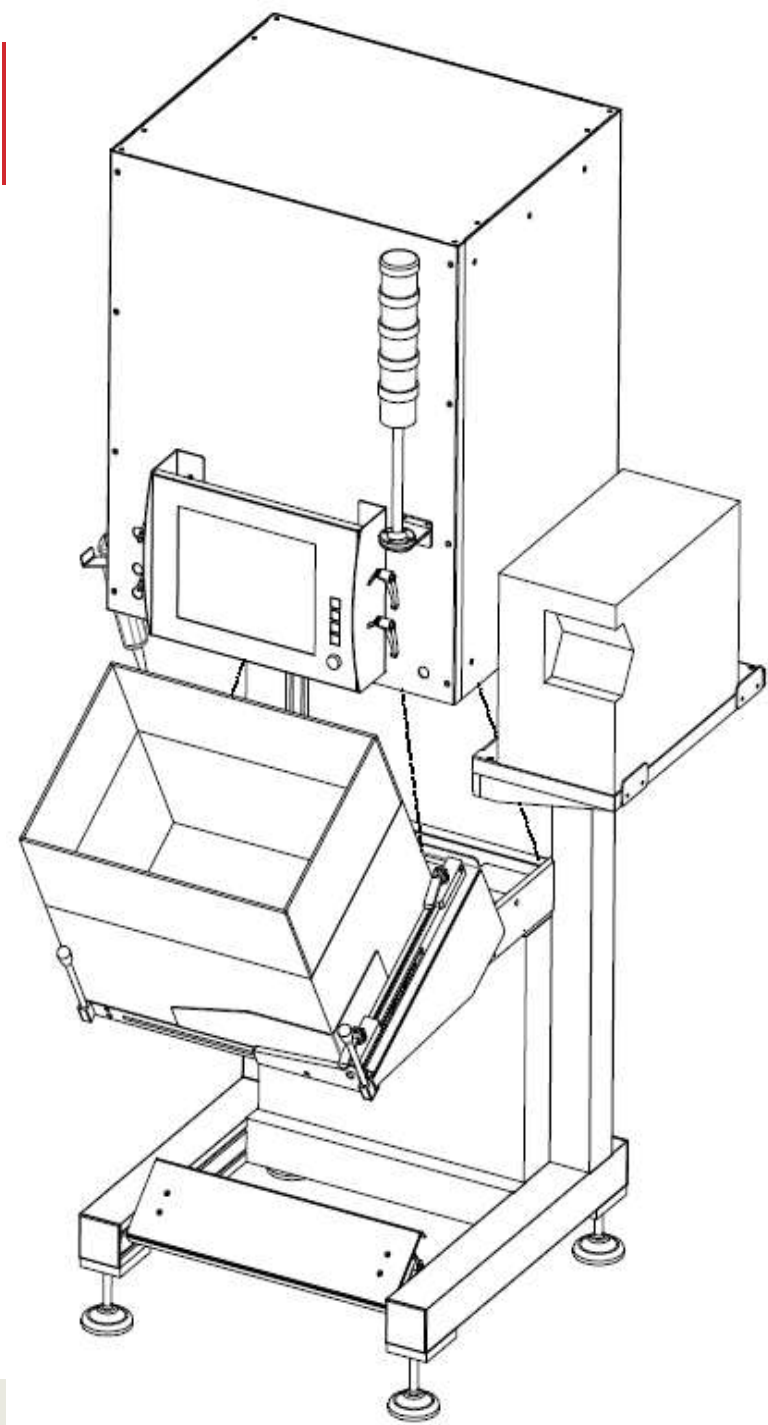

# Track & Trace Antares Vision AGREGAÇÃO – Item CAIXA DE EMBARQUE



● Para 1 camadas de cartuchos

# Track & Trace Antares Vision AGREGAÇÃO – Item CAIXA DE EMBARQUE



● Para linhas de produção de baixa performance

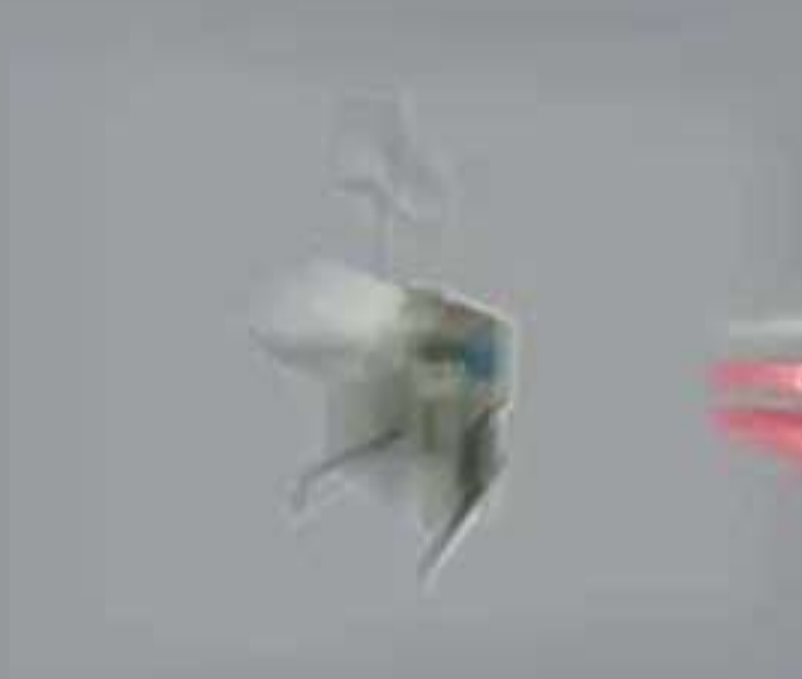

SWIMMING  
WATER

# Track & Trace Antares Vision AGREGAÇÃO – Item CAIXA DE EMBARQUE



- Para linhas de produção de baixa performance e baixo custo de implementação

# Track & Trace Antares Vision



**100 % RASTREABILIDADE**

Solução completa de rastreabilidade de medicamentos para a indústria farmacêutica



[www.antaesvision.com](http://www.antaesvision.com)

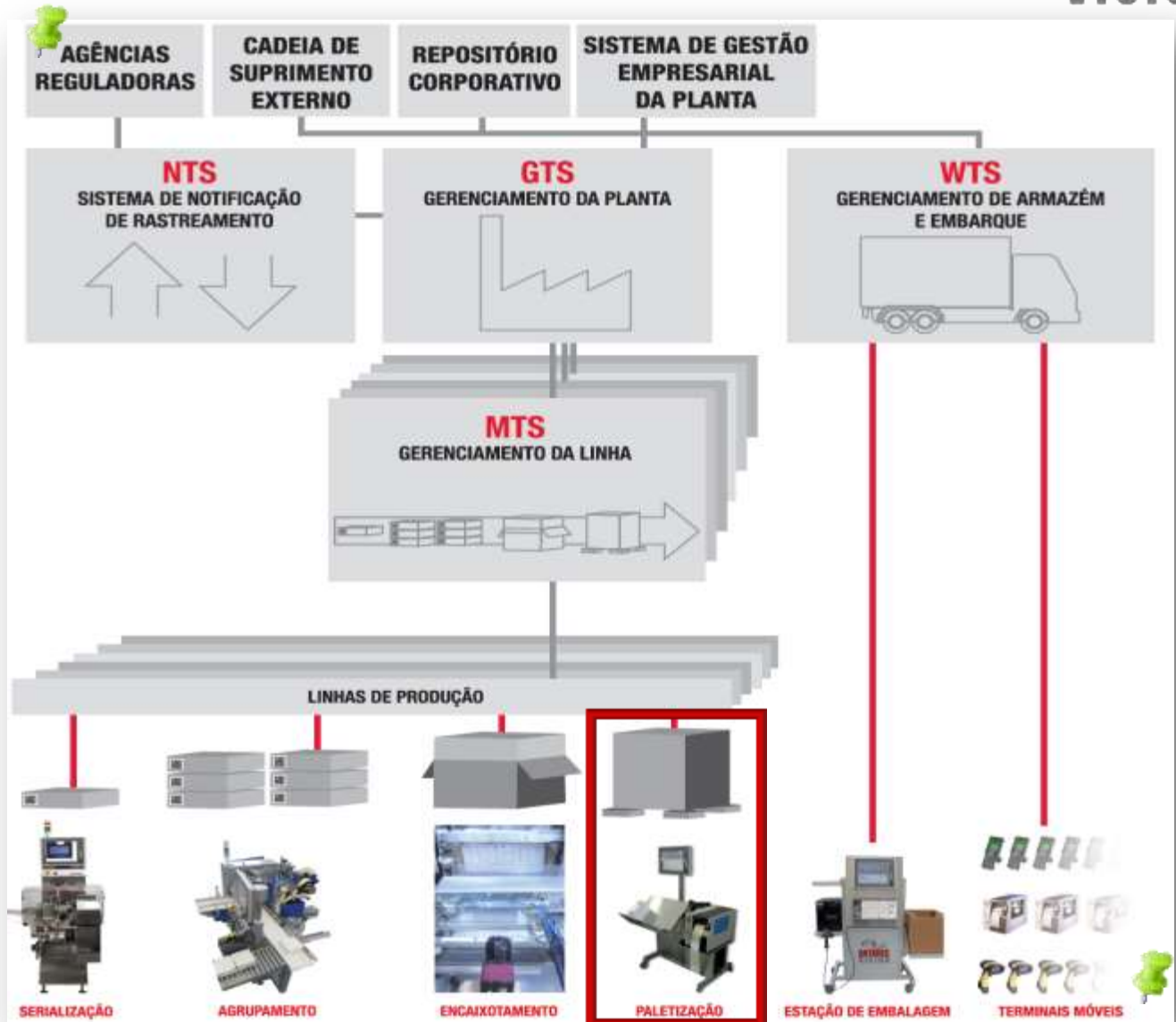

YOUR INSPECTION AND TRACEABILITY PARTNER

# Track & Trace Antares Vision AGREGAÇÃO – Item PALLET



- Para linhas de produção com formação Pallet manual

# Track & Trace Antares Vision



**100 % RASTREABILIDADE**

Solução completa de rastreabilidade de medicamentos para a indústria farmacêutica



[www.antaesvision.com](http://www.antaesvision.com)

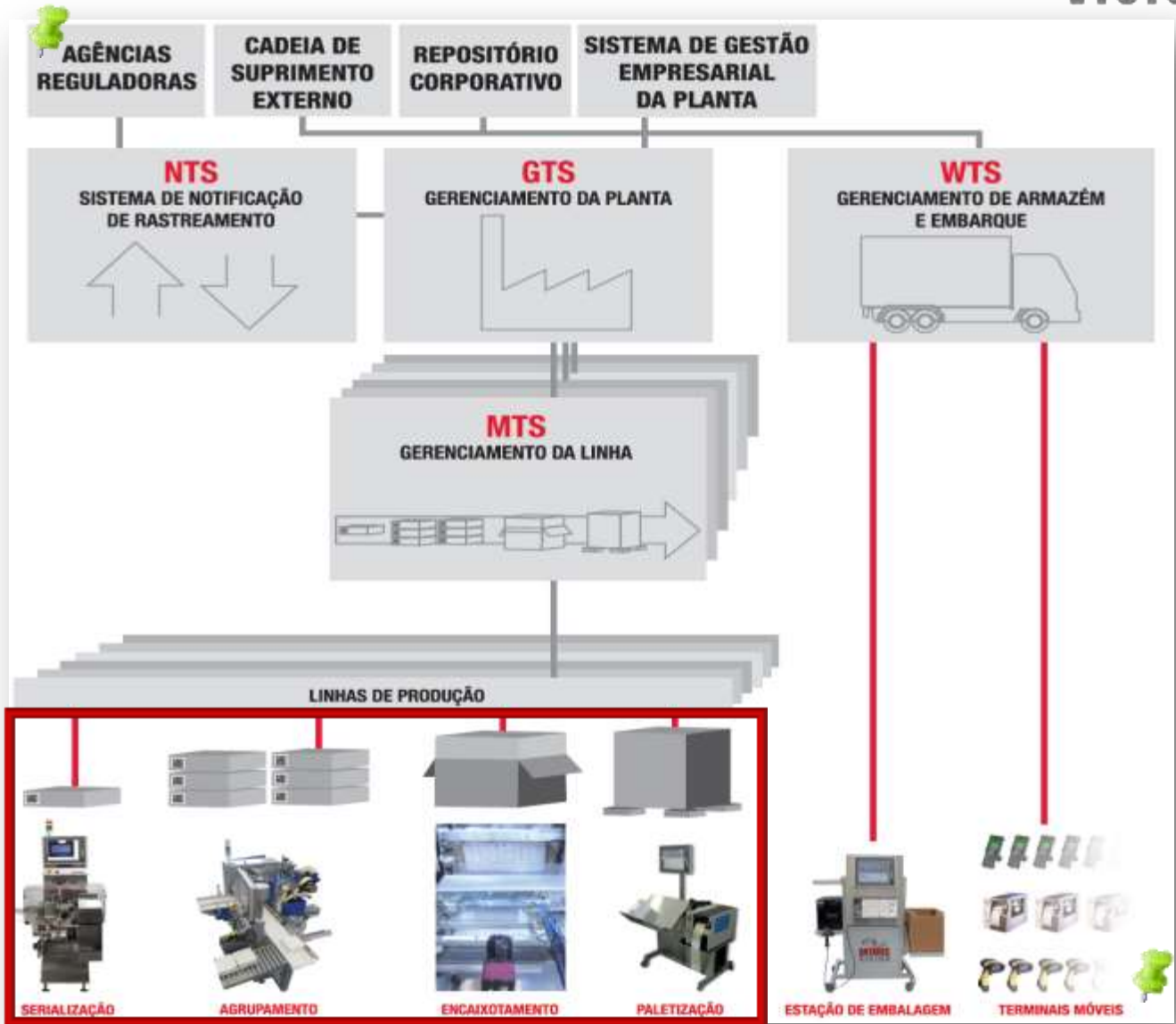

YOUR INSPECTION AND TRACEABILITY PARTNER



# Track & Trace Antares Vision OVERVIEW - APLICAÇÕES



## LINHA MANUAL



YOUR INSPECTION AND TRACEABILITY PARTNER

# Track & Trace Antares Vision OVERVIEW - APLICAÇÕES



## LINHA AUTOMÁTICA



YOUR INSPECTION AND TRACEABILITY PARTNER

# Track & Trace Antares Vision



**100 % RASTREABILIDADE**

Solução completa de rastreabilidade de medicamentos para a indústria farmacêutica



[www.antaesvision.com](http://www.antaesvision.com)

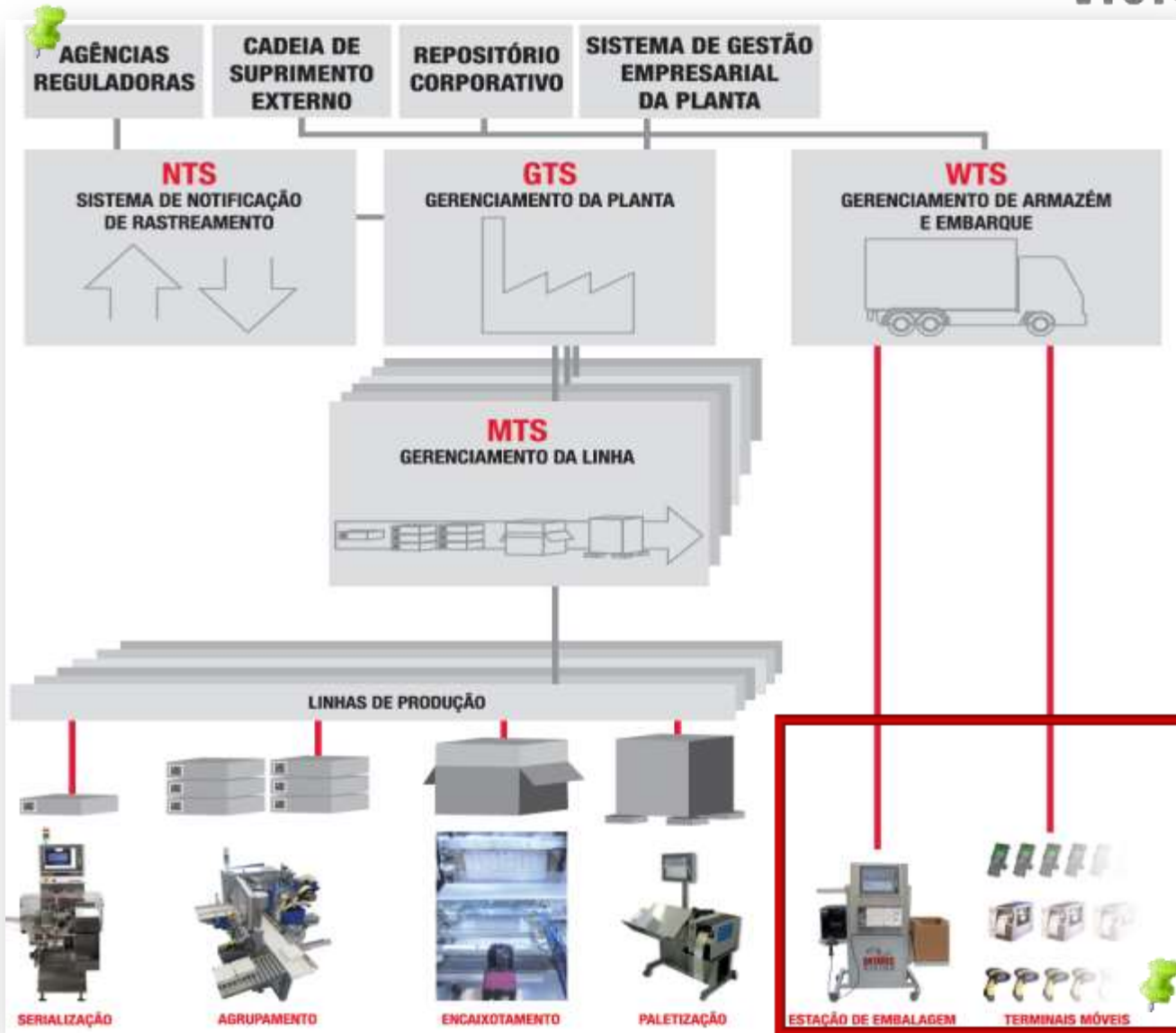

YOUR INSPECTION AND TRACEABILITY PARTNER

## CONCEITO E ATIVIDADES

- **WTS - Warehouse Tracking System** é a solução completa para preparar os embarques na área de armazém ou centro de distribuição, permitindo o desmantelamento e re-agregação de conteúdos completos ou incompletos ou mix-conteúdos, por meio de dispositivos automático ou manual.
- **WTS administra** recepções ordem bem das operações de embarque ERP e para os clientes finais.
- **Quando os produtos são enviados**, o módulo interage com os sistemas de rastreamento externos para manter o histórico dos pacotes de acordo com as recomendações das Autoridades (futuro ANVISA)

### **FUNÇÕES BASICAS:**

- 1- criar caixas ou pallets completos ou incompletos
- 2- criar mix-conteúdos
- 3- abrir caixas previamente criadas, a fim de modificar o seu conteúdo ou para preenchê-lo, movendo itens de um recipiente para outro, ou com novos itens
- 4- adicionar ou remover o recipiente para embalagem vinda diretamente da linha de produção
- 5- adicionar ou remover um código de barras no interior de um contentor
- 6- imprimir etiquetas de expedição, utilizadas para identificar o recipiente padrão provenientes da linha de produção e previamente associado com a ordem de embalagem
- 7- processar a recepção de produção de terceiros

# Track & Trace Antares Vision WAREHOUSE - APLICAÇÕES



## CONCEITO E ATIVIDADES - EXEMPLO DE ATIVIDADES



YOUR INSPECTION AND TRACEABILITY PARTNER

Obrigado por sua atenção!  
Visite nossa linha DEMO  
- Agende com os números abaixo!



Antares Vision Brasil  
Rafael Latorre  
+ 55 11 99528-1210

[rafael.latorre@antaresvision.com](mailto:rafael.latorre@antaresvision.com)  
[sales.br@antaresvision.com](mailto:sales.br@antaresvision.com)